



Effect of TiO₂ addition on crack propagation of alloy 600 and its penetration into crevices in caustic solution

Uh Chul Kim ^{*}, Kyung Mo Kim, Jung Soo Kang, Eun Hee Lee, Hong Pyo Kim

Korea Atomic Energy Research Institute, P.O. Box 105, 305-600 Yusong, Daejeon, South Korea

Received 19 September 2001; accepted 11 February 2002

Abstract

A number of tubes of nuclear steam generators have experienced stress corrosion cracking in environments thought to be caustic. Wedged CT specimens of Alloy 600 were used to measure crack propagation rates with and without TiO₂ in a 10% NaOH solution at 315 °C. The crack propagation rate was reduced by 1/2 with 2 g/l TiO₂ addition. Polarization curves showed an extensive decrease of the anodic peak current and passive current with TiO₂ addition in a 10% NaOH solution at 315 °C. The TiO₂ penetration into crevices was investigated using Alloy 600 specimens having different gap sizes in a 1% NaOH solution at 315 °C with TiO₂ addition. The Ti concentration of the specimens was analyzed in crevices by Auger electron spectroscopy after a 3-day exposure. The Ti concentration was 42% or more in crevices wider than 0.2 mm and 20% in the narrowest crevice with 0.05 mm. © 2002 Elsevier Science B.V. All rights reserved.

1. Introduction

Many nuclear power plants have experienced the stress corrosion cracking of their steam generator tubing in environments thought to be caustic. Some researchers reported the effect of inhibitors including TiO₂ on the caustic induced stress corrosion cracking of Alloy 600 steam generator tubes [1–4] and available data are limited. The objectives of this research are to investigate the electrochemical characteristics and crack propagation rate and to check the degree of TiO₂ penetration into crevices with different gap sizes, in a caustic solution with and without TiO₂.

2. Experimental

Wedged CT specimens were used for stress corrosion cracking tests. The thickness of the specimens was 10 mm. As shown in Fig. 1, the specimens were machined to a depth (15.3 mm) with a side groove (10% of thick-

ness) on each side. The specimens were wedged to have a $\Delta L = 1.4$ mm. The crack propagation was monitored by a DC potential drop measurement (Keithley model 182 sensitive digital voltmeter, model 228 A voltage/current source). The potentials of the specimens were applied by a PAR 273 potentiostat using a Ag/AgCl reference electrode (Fig. 2). TiO₂ powder from Degussa was used and it has a range of particle size from 0.06 to 0.2 μ m (Table 1). The CT Specimen was made of Alloy 600MA which was solution-annealed for 2 h at 1025 °C and water-quenched. It contains 0.032% carbon (Table 2).

In order to investigate the penetration of TiO₂ into crevices, the specimens were machined with different gap sizes. An upper part and a lower part were bolted together as shown in Fig. 3. Specimens were exposed to the solution for 72 h without and with crevice flushing. The Ti concentration in an oxide layer was analyzed using Auger electron spectroscopy (AES).

3. Results and discussion

The crack propagation of Alloy 600 specimens was measured by a DC potential drop method at two different potentials in a 10% NaOH solution at 315 °C as

^{*} Corresponding author. Tel.: +82-42 868 2363; fax: +82-42-868-8696.

E-mail address: uckim@kaeri.re.kr (U.C. Kim).

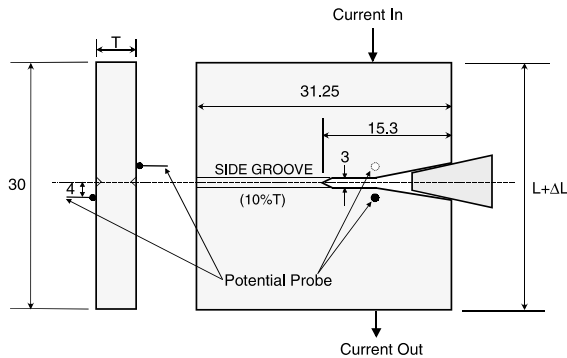

Fig. 1. Schematic drawing of wedged CT Specimen (unit: mm).

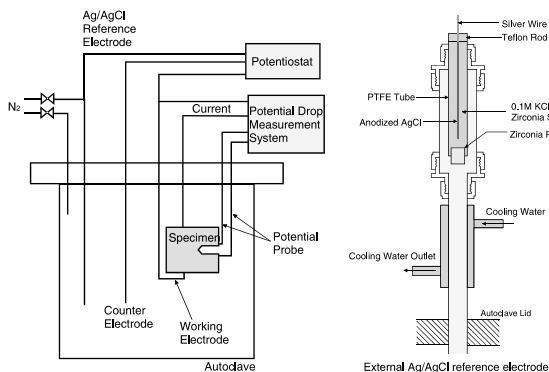

Fig. 2. Experimental set-up of stress corrosion cracking with DCPD.

Table 1
Properties of Degussa P25 TiO₂ powder

Surface area (m ² /g)	50 ± 15
Effective particle size (μm)	0.06–0.2
Drying loss (%)	<1.5
Ignition loss (%)	<2
SiO ₂ (%)	<0.2
Al ₂ O ₃ (%)	<0.3
Fe ₂ O ₃ (%)	<0.01
TiO ₂ (%)	<99.5
HCl (%)	<0.3
Crystal structure (%)	Anatase (82), Rutile (18)

Table 2
Chemical composition(wt%) of Alloy 600 CT specimen

Element	C	Cr	Ni	Fe	Ti
wt%	0.032	15.51	75.32	7.9	0.39

shown in Fig. 4. The potential was applied relative to its corrosion potential and the crack was more rapidly

propagated at 150 mV than at 200 mV. The change of the crack propagation rate was investigated at 150 mV in the 10% NaOH solution at 315 °C with and without TiO₂ in Fig. 5. When the TiO₂ powder was added to 2 g/l, the crack propagation was reduced by 1/2. The cracked surface of the specimen was investigated by SEM, after the specimen was exposed to the solution at 150 mV and 315 °C with TiO₂. Cracks were propagated more rapidly on each side from a machined notch area. The enlarged picture of the cracked surface indicates intergranular stress corrosion cracking.

The polarization curves were obtained for the Alloy 600 specimen in the 10% NaOH solution at 315 °C with and without TiO₂ in Fig. 6. The active peak current density and passive current density were reduced greatly by the addition of 2 g/l TiO₂. The change of the active peak current density and passive current density might improve the resistance to stress corrosion cracking and might be associated with the formation and distribution of the titanium composition of the passive layer on the Alloy 600 specimen.

When the specimen was exposed for 3 d in the 1% NaOH (pH = 12.7) solution at 150 °C without TiO₂ addition, the AES results showed that the Ti ratio was negligible as shown in Fig. 7. However, the Ti ratio was distributed in the layer containing oxygen and the maximum value of Ti was observed inside of the layer as shown in Fig. 8 for an example, when the specimen is exposed for 3 d to the solution containing 2 g/l TiO₂.

The TiO₂ penetration was investigated in a 1% NaOH solution containing 2 g/l TiO₂ at 150 °C. The specimens were immersed for 3 d and atomic ratios were measured by AES at the position (edge) of 2.5 mm from A–A line in Fig. 3. Fig. 8 shows depth profiles of elements in the film on Alloy 600 with a crevice gap of 0.2 mm. An oxygen level decreased and reached 0% by sputtering for about 4200 s and a titanium level showed the maximum value of 21% after sputtering for 500 s. The crevice gap size effect on the penetration of TiO₂ was shown in Fig. 9 in the 1% NaOH solution containing 2 g/l TiO₂ at 150 °C without a crevice flushing. The maximum concentration of Ti during the sputtering was analyzed among the metallic atomic ratios of the maximum Ti, Cr, Fe and Ni. When the crevice gap is wider than 0.2 mm, the Ti ratio is higher than 42%. This ratio is 18% in the case of a 0.05 mm gap size and 12% in the case of a closed gap at which is bolted together. This indicates that the titanium oxide is considerably penetrated into the crevice of the 0.05 mm gap and even into the closed gap. In order to check the Ti ratio of base metal as a reference, it was tested in the same experimental condition for 3 d without a TiO₂ addition and the Ti ratio is less than 1% as shown in Fig. 7.

In order to increase the penetration of TiO₂ into the crevices, two kinds of crevice flushing were applied to the specimens in the same solution at 150 °C. A pressure

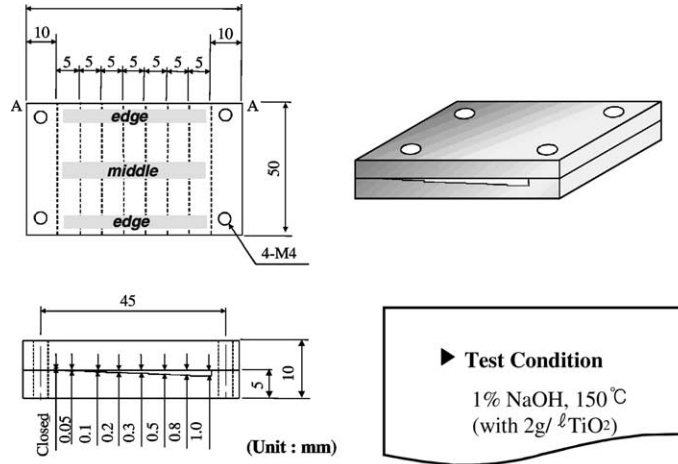

Fig. 3. Schematic drawing of specimen with different crevice gaps.

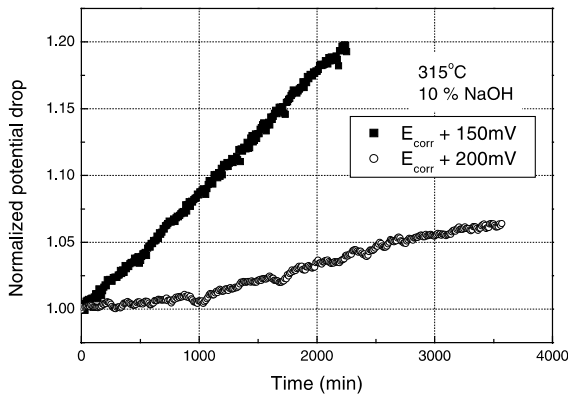

Fig. 4. Crack propagation of Alloy 600 in 10% NaOH at 315 °C at potentials of $E_{corr} + 150$ mV and $E_{corr} + 200$ mV.

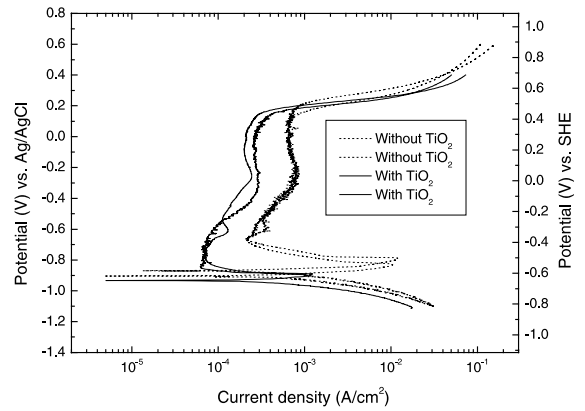

Fig. 6. Polarization curves for Alloy 600 in 10% NaOH at 315 °C with/without TiO_2 .

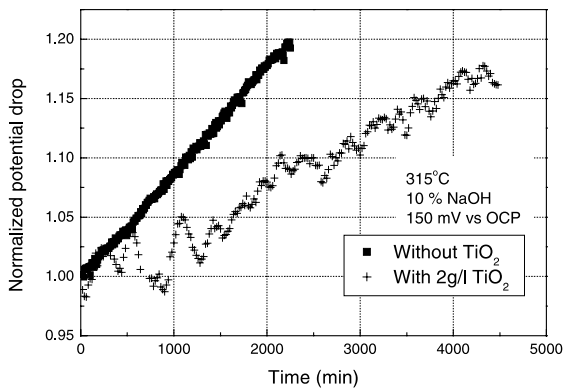

Fig. 5. Crack propagation of Alloy 600 in 10% NaOH at 315 °C with/without TiO_2 .

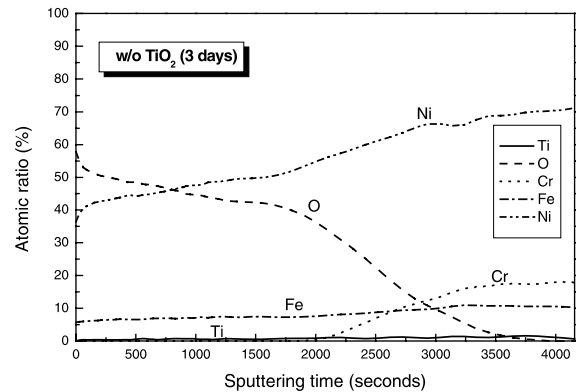

Fig. 7. AES depth profiles of the elements in the film formed on Alloy 600 in 1% NaOH solution at 150 °C without TiO_2 .

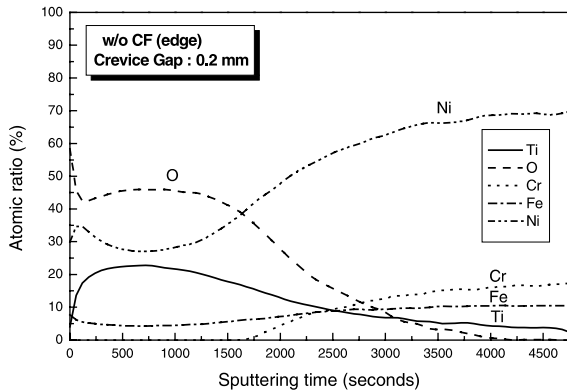

Fig. 8. AES depth profiles of the elements in the film formed on Alloy 600 with a crevice gap 0.2 mm tested in a 1% NaOH solution containing 2 g/l TiO_2 at 150 °C.

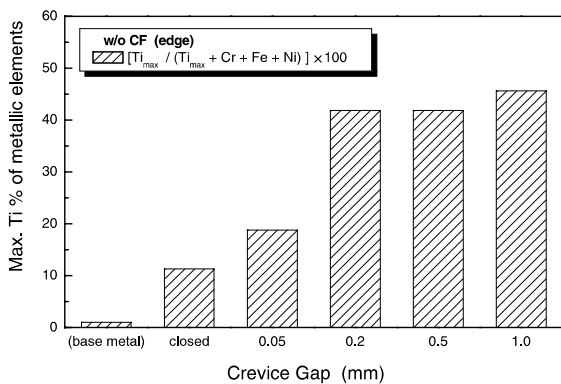

Fig. 9. Crevice gap size effect on the maximum Ti concentration in oxide layer.

drop was performed by 1 bar in 18 min and repeated 4 times for the crevice flushing 1 (CF1). The pressure was dropped by 1 bar in 15 s and this procedure was repeated 4 times for the crevice flushing 2 (CF2). The specimens were exposed to the solution at 150 °C for 3 d after these crevice flushings. The crevice flushing 1 increased the maximum Ti ratio of metallic elements in Fig. 10. However, the crevice flushing 2 could not increase the Ti value. AES results showed that the layer containing oxygen was reduced more by the more vigorous crevice flushing (CF2).

The ratio of the maximum Ti in metallic elements was plotted in Fig. 10 at two different locations, 2.5 and 22.5 mm from the A–A line of the specimen. This value decreased from 18% at the position of 2.5 mm to 8% at the position of 22.5 mm for the case of 0.05 mm gap size without the crevice flushing. However, it did not change much at two different locations for the case of 0.2 mm gap size without and with the crevice flushing. The Ti penetration was changed much depending on the depth

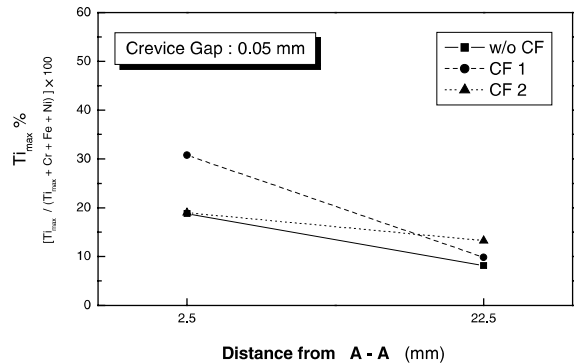

Fig. 10. Maximum Ti concentration in oxide layer of Alloy 600 Specimen with 0.05 mm crevice gap at different locations.

of crevice for the narrow gap (0.05 mm). However, it was not changed much for the wider gap (0.2 mm).

When the TiO_2 powder is injected into steam generators of nuclear power plants, TiO_2 will be dissolved in a caustic solution provided due to the local boiling and concentration of impurities in crevices. It can change the composition of Ti of the passive layer and this change of Ti composition at the crack tip will improve the electrochemical characteristics of the steam generator tubing and reduce the crack propagation rate. A further research work is needed to check the change of repassivation rate when TiO_2 is added. It will be important to penetrate the TiO_2 more effectively into the crevice by investigating the effect of chemical forms of TiO_2 and injecting procedures of TiO_2 even with piled-up sludge.

4. Conclusions

- When the TiO_2 powder is added in a 10% NaOH solution at 315 °C, the crack propagation rate of Alloy 600 is reduced greatly at 150 mV relative to E_{corr} .
- The active peak current density and passive current density decreased much by the addition of TiO_2 in the same environment.
- The Ti concentration could be detected in considerable amounts, 18% in the case of 0.05 mm gap size and 12% even in the case of a closed gap where the specimens were bolted together. It was higher than 42% when the gap was wider than 0.2 mm after an exposure in 1% NaOH at 150 °C.
- Depending on the condition of crevice flushing, the Ti concentration could increase in the crevice.

Acknowledgements

This work was funded by Korea Ministry of Science and Technology.

References

- [1] J. Daret, J.P. Paine, M. Partridge, Model boiler testing to evaluate inhibitors for caustic induced stress corrosion cracking of Alloy 600 tubes, in: Proceedings of the 7th International Symposium on Environmental Degradation of Materials in Nuclear Power Systems–Water Reactors, Breckenridge, CO, August, 1995, p. 177.
- [2] J. Lumsden, S. Jeanjaguet, J.P.N. Paine, A. McIlree, Mechanism and effectiveness of inhibitors for SCC in a caustic environment, in: Proceedings of the 7th International Symposium on Environmental Degradation of Materials in Nuclear Power Systems–Water Reactors, Breckenridge, CO, August, 1995, p. 317.
- [3] M. Miglin, J. Monter, C. Wade, M. Psaila-Dombrowski, A. McIlree, SCC of Alloy 600 in complex caustic environments, in: Proceedings of the 7th International Symposium on Environmental Degradation of Materials in Nuclear Power Systems–Water Reactors, Breckenridge, CO, August, 1995, p. 277.
- [4] B. Miglin, J.P. Paine, Slow strain rate testing to evaluate inhibitors for stress corrosion cracking of Alloy 600, Proceeding of the 6th International Symposium on Environmental Degradation of Materials in Nuclear Power Systems–Water Reactors, San Diego, CA, 1993, p. 303.